

SSR Aux Fan Installation

- **It is highly recommended that you read these instructions all the way through before beginning the installation. Doing so will most likely save some rework.**
- Although this installation can be accomplished by one person, some of the steps are best done with a second set of hands involved.
- **The fan has already been set to the “Pusher” configuration. DO NOT reconfigure the fan blade.**

Aux Fan Features and “Normal” SSR Cooling System Operation:

The Aux Fan is a pusher that goes directly in front of the A/C condenser. It does not conflict with the flow of the OEM cooling fan in any way.

The Aux Fan is turned on any time the SSR computer system commands the main fan to run. The details of this operation are included in the Cooling System “Description and Operation” section in the Service Manual and may vary slightly from one model year to the next. Generally speaking, the main fan will be commanded on at 226 degrees F (low speed) and at 235 F (high speed) rising temperature and off at 219 F (high goes to low at 226 F) falling temperature. If the coolant temp is above 185 F and the A/C is on, the cooling fan will be commanded on according to A/C system pressure values. In this case, **the Aux Fan will improve A/C operation in hot climates and in stop-and-go traffic.**

In addition to the SSR computer driven functions, the Aux Fan has its own adjustable temperature switch. This provides several positive features:

- **The ability to provide a cooling system set point just slightly lower than the computer controlled point.** This will provide OEM fan with enhanced longevity and improve system temperature stability in stop and go traffic. I recommend a set point between 205 and 215 degrees F.
- **The ability to run the Aux Fan after the ignition switch is turned off.** This will greatly assist in removing trapped heat from the cooling system after shutdown and reduce the amount of engine compartment residual heat.
- **The safety of a “back-up” cooling system fan in case anything in the OEM cooling system fails.** The Aux Fan has enough capacity to provide a “get me home” margin of safety, as it will run any time the cooling system is above the temperature switch set point. In the event of a main fan failure, turn off the A/C when driving below 35 MPH.

Parts in the Kit:

1. Fan with brackets and hardware
2. Controller with bracket and wiring harness
3. Fan power “break-in” connector set
4. 6 Black Nylon Tie wraps
5. 8” Strip of 3M “425” Aluminum Tape
6. White wooden tool for radiator fin movement
7. Installation Instructions, including Flex-A-Lite reference information

Tools Recommended:

- 10mm open end wrench
- 8 and 10mm socket and ratchet with 4" and 12" extensions
- 12" long flat blade screwdriver
- Diagonal cutters
- Needle Nose Pliers
- Scissors
- Masking tape

Remove or Disconnect:

1. THIS IS IMPORTANT!

- Lower both windows before disconnecting battery. Without power, the windows will not be able to "index" and allow the door to be opened.
- Disconnecting the battery will erase some of the PCM settings, such as short term and long term airflow trim tables. These will be restored by the PCM automatically. Radio and seat position presets may also be lost.

2. Remove Battery cover and disconnect negative battery cable.

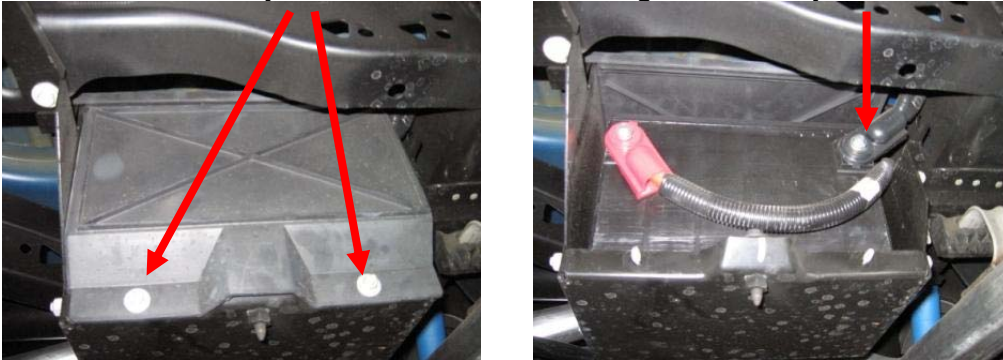

3. Remove upper radiator panel cover. Two nuts and two plastic fasteners.

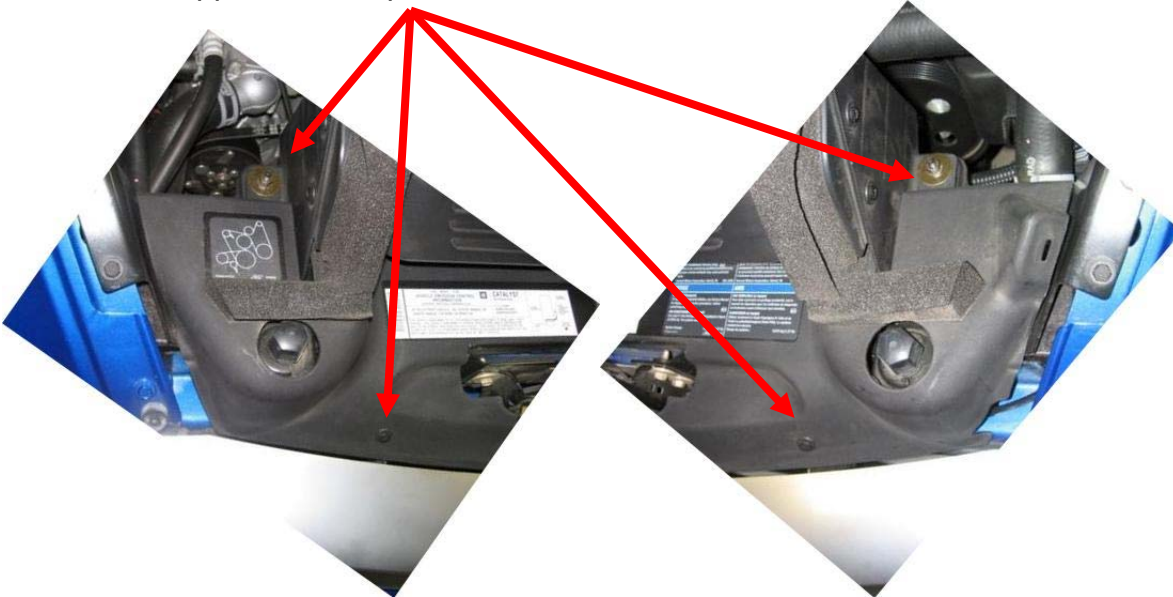

4. Removal of the Air Cleaner assembly is required. Just remove the front bolts and loosen the large hose clamp on the air filter assembly closest to the intake manifold, and lift out and place up out of the way as shown.

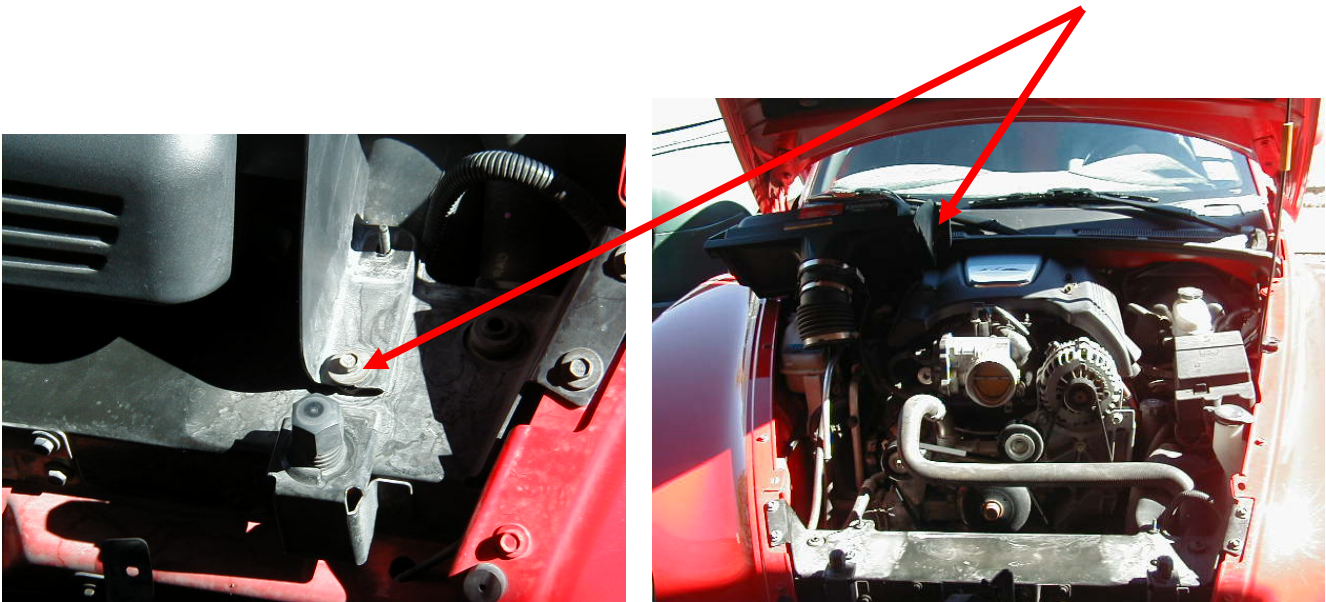

5. Remove cross member air guide with a flat tip screw driver to push down and pry away from the cross member, and pull forward and out to expose the wiring harness mounts.

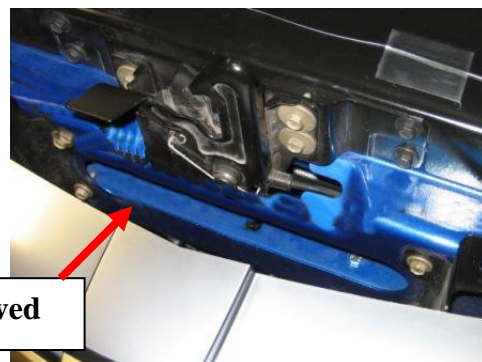
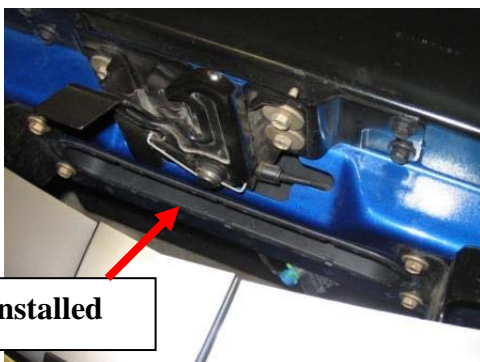
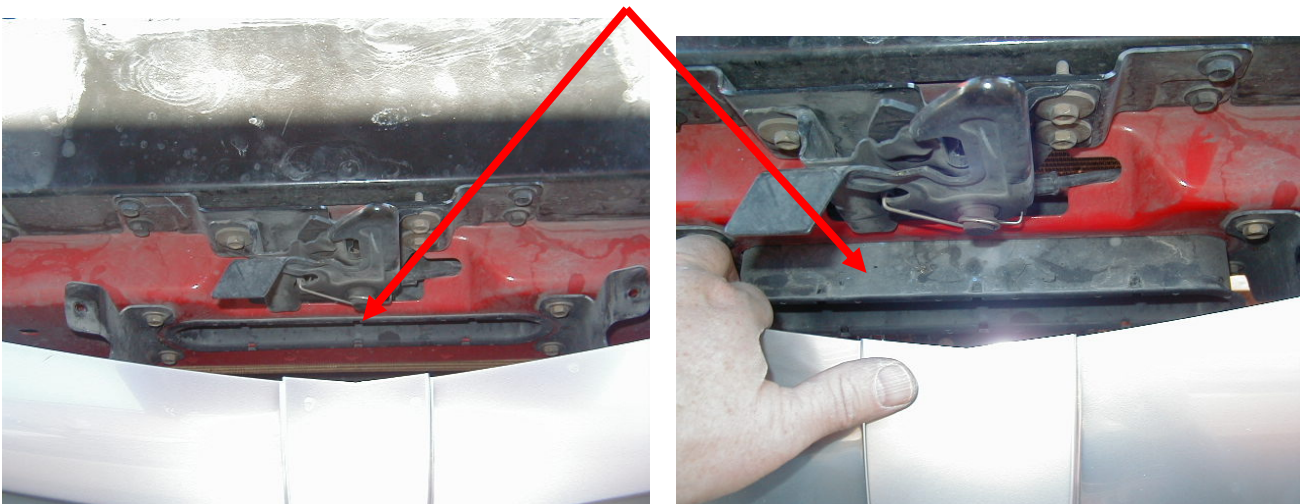

6. Disconnect cross-frame wiring harness mounts by carefully pressing the locking tabs toward the center of the tab and allow it to drop out the bottom of the frame. Be patient.

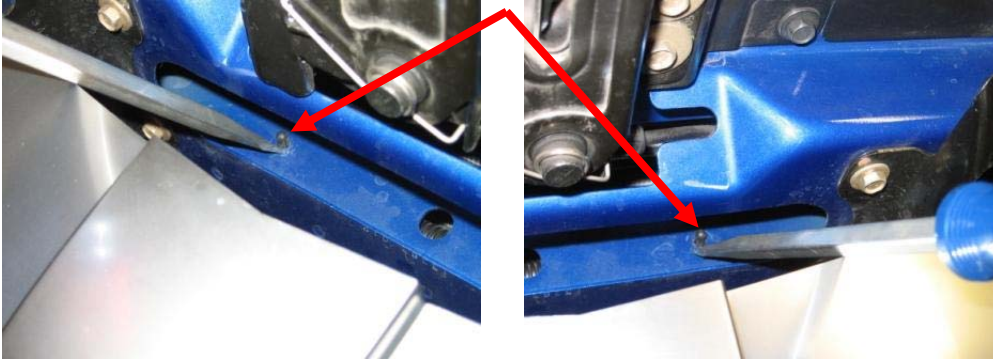

7. After dropping the wire harness from the cross-frame, remove the two wire harness clamps from the harness. You will be installing it in the center of the upper fan bracket.
8. Remove and store air dam center retainer. It is not necessary to remove any others.



9. Disconnect electric cooling fan 3 pin power connector. It is best to use two hands, one on each of the two connectors. Pulling vigorously may unwontedly disengage the connector from the mount to the fan bracket.



10. Remove engine compartment fuse block outer cover.



11. Remove 8 (the two sets of four) mounting bolts on the upper radiator mounting panel in order to remove the panel assembly from the truck. **DO NOT** remove the two that hold the hood latch to the cross member, or you may mess up your hood adjustment!!! They are the **BOTTOM** two of the hood latch attachment. The hood latch will still be connected to the cross member.

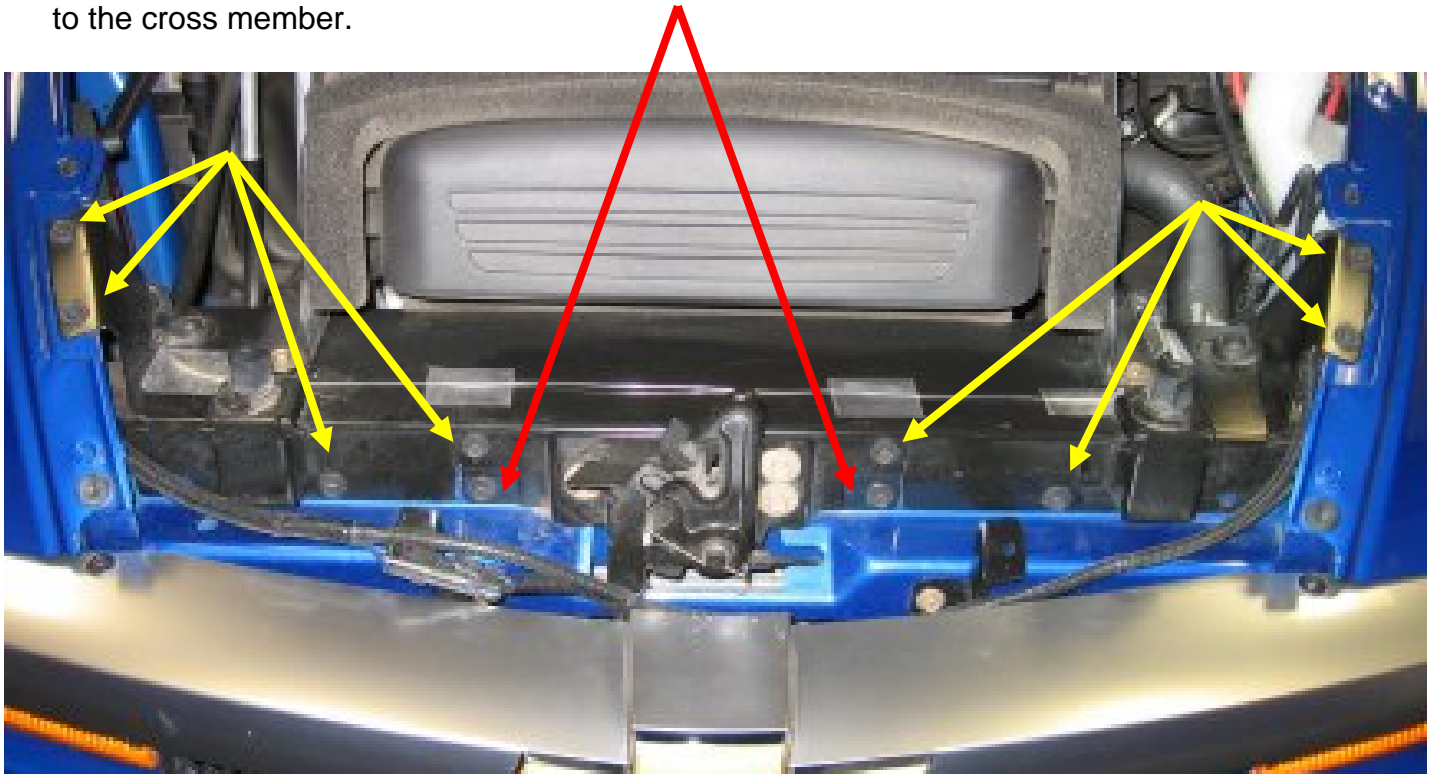

12. Remove right forward fender mounting bolt.



Install Fan:

1. Remove the two loose bolts from the upper fan bracket of the auxiliary fan. You'll need them for step 3, below. Insert one of the wire harness clamps removed earlier into the fan side of the open **center** hole in the upper fan bracket to support the wire harness after the fan is in place.
2. Remove the single black-headed bolt from the lower fan bracket. Slide the fan assembly up the front of the condenser and get it past the wire harness to the bottom of the cross member. This should provide approximate alignment with the lower radiator support for the lower fan bracket bolt hole. Insert the black-headed bolt back through the lower bracket and lower radiator support and install the nut on the back side without tightening. This will hold the fan for now.
3. Position the upper fan bracket to line up with the holes from the wiring harness mounts and drop in the upper fan bracket bolts through. A screwdriver (or finger) can be used to position the bracket through the large center hole in the frame cross member, while dropping the bolts in place with needle-nose pliers.

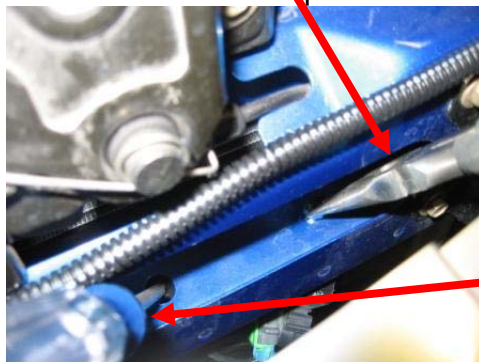

4. While holding the upper mount bolts, loosely install both nylon locking nuts. If you have an '06, your temp sensor is on a metal bracket attached to the left wiring harness mount, you can relocate the bracket under the nut of the left mount bolt. This is difficult to do and requires extra hands. Earlier models may have the temp sensor taped to the wire harness. You can either leave this as is, or tie wrap the sensor to the harness.
5. Tighten both upper fan bracket bolts through the frame cross member. The mount system is designed to carry the weight of the fan from above. The lower mount is intended as a locator only and should not actually carry the weight or have any "preload" in any particular direction. A misalignment of the mounting system will show at this point at the lower fan bracket. If you have a minor misalignment, you should be able to clear it by loosening the bracket to Aux Fan nuts and repositioning the lower bracket a little on the fan itself. If you have a major misalignment, call me.
6. Tighten the lower fan bracket mount bolt through the lower radiator mount and air dam.
7. Insert the wire harness into the clamp at the center of the upper fan bracket and latch it closed.

Install controller and wire harness:

1. Mount the controller and the ground terminal using the fender mounting bolt from step 9 of Removals. The controller mounting is designed to slightly pinch the convoluted tubing between the top of the controller and fender.



2. Route the controller wiring harness forward along the fender so that it will pass under the (currently removed) radiator mounting panel. There will be enough room for everything when re-installing the panel.

Also, be careful not to damage the sensor capillary tube coiled up on the controller. It will have separate routing – **DO NOT** route it with the wire harness.



Note: Upper radiator mount shown installed for routing reference only.

3. Route the wiring harness across the front (reference picture in step 11 of removals) and up along the left fender where the (currently removed) radiator mounting panel is going to be re-installed.

Note: Upper radiator mount shown installed for routing reference only.

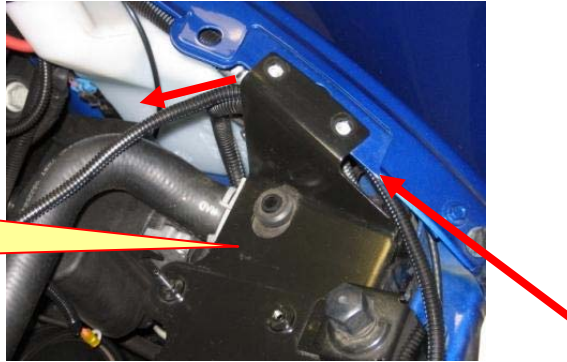

Please note that the following 3 steps use photos that show the upper radiator panel and other hardware installed. This is for reference only.

4. If you are installing on an '03-'04, you will have to move the large control module to gain access to the left side of the radiator core. Remove the two bolts from the plastic bracket that holds the module, and rotate it aft to get to the back of the radiator. This should give you access to the radiator core to prepare an opening for the coolant temperature sensor.



5. You must now **carefully** prepare a path for the coolant temperature sensor to reside in the radiator fins. Use the wooden tool (looks like a golf tee) in the plastic baggie to **carefully** create space through the radiator fins for the sensor. The size of the special tool is just right for preparing a nice tight fit of the temp sensor. When I did this for the first time on my truck, I used a #1 Philips screwdriver and held my breath the whole time.

The passage you create in the core should be about 1 inch inboard of the driver's side tank in the second row of fins.



Remove and discard the soft plastic cap off the end of the coolant temperature sensor and slide the sensor into the radiator. It should fit snugly and should have most of the large bulb end inserted. Insert the sensor until it reaches the red tape on the sensor or until there is about $\frac{3}{4}$ " of bulb remaining uninserted. Pushing the sensor too far into the radiator core will cause it to protrude too far out the front of the radiator, resulting in degraded thermostatic operation. Slide the black corrugated protective covering all the way to the radiator core, covering the red tape.

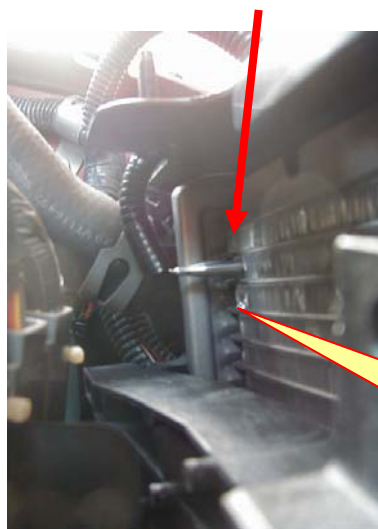

Note: Protective covering is shown pulled back to show proper depth. Push covering flush to radiator.

6. Re-install upper radiator mounting panel. Be sure that the outer bolts do not pinch the corrugated tubing passing under them.

7. Carefully route the capillary tube across the radiator mounting panel. Use masking tape to temporarily hold in place as needed.



8. Re-install the air box onto the upper radiator support. Be sure the capillary tube protective cover over the temperature sensor is flush with the radiator core. Tape the corrugated tubing to the upper radiator support, forcing it into the corner at the air box with a piece of the aluminum tape provided. Leave a small, smooth service loop curving down to the sensing bulb.



9. Use additional pieces of the aluminum tape to route the capillary tube safely across the radiator mounting panel. Avoid the two corner areas where the capillary tube passes by the air cleaner mount. Pinching of the capillary tube is possible at the corners. This is a bad thing and must be avoided. Remove the masking tape used earlier.



10. Unscrew the fan power connection at the fuse block and add the terminal on the end of the wiring harness. Do not re-bend the terminal lug and be careful to position it exactly as shown (it actually comes “up” off the forward, driver’s side corner of the block) in order to properly clear the cover. Tighten the nut onto the terminal.



11. Re-install the fuse block outer cover. Be careful to route the new wire to clear the cover.

12. You may want to move the air cleaner out of the way again. Install the “break-in” connector set to the fan connector and re-connect the stock wiring harness disconnected in the “Removals” section. Place tie-wrap around fan support leg and the connector set wiring. A white cable tie shown for clarity.



13. Mate the single pin connector to the harness and stow the fuse holder along fender.



14. Mate the 2 pin fan connector to the wire harness and add tie wraps to hold fan wiring as shown. The center one is horizontally around the vertical part of the hood latch bracket.

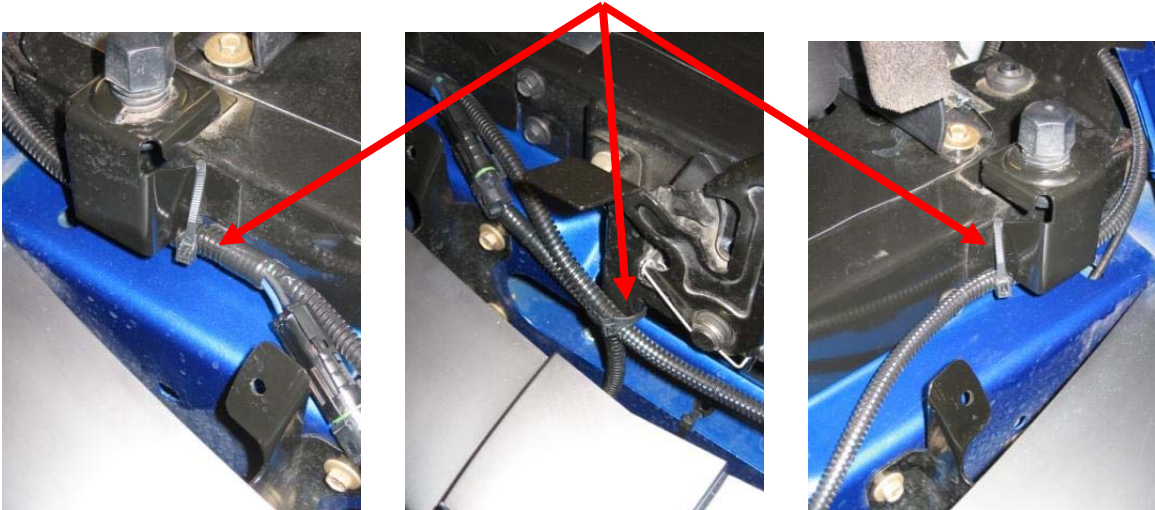

15. Check from below to be sure all wiring is held clear of the fan.



Viewed from the driver's side, looking up.



Finishing up:

1. Re-install the command module on your '03-'04.
2. Re-install the cross-member air guide (Optional).
3. Re-install the upper radiator panel cover. I recommend you trim the corner off that impacts the convoluted tubing above the temperature sensing bulb. A small nip with some snips and a little file work is all that is needed. This will avoid crushing the convoluted tubing.

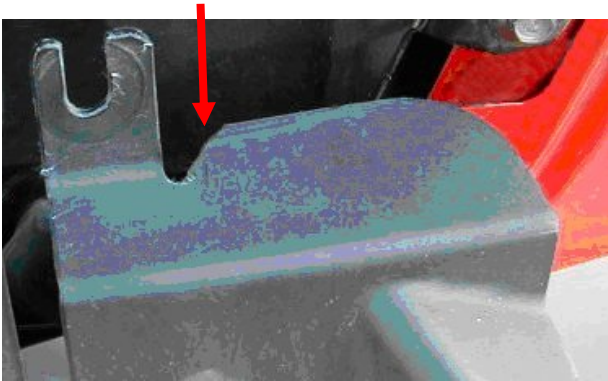

4. Reconnect the negative battery cable and battery cover. Your truck may go through a new “learning” of PCM parameters and you may have to re-do your radio and seating presets.

Thermostat Information:

The Flex-a-lite 30332 control module has a temperature set point range from approximately 160 to 240 degrees F. The control is shipped with a setting **below** the 210 (+/- 5) degree set point that I recommend so that you can calibrate it to your truck. Use your own judgment on how much you want this fan to run based on the “normal” operating temperature of your vehicle. You will have to monitor the “after shutdown” fan operation and make minor adjustments to suit your own particular needs.

Thermostat Adjustment:

Start with the “below mid-point” setting that I shipped the controller and follow these steps:

1. Start your truck and let it idle with the **A/C off** and the recirculate function deselected. This will bring the coolant temp up slowly to the point where the Aux Fan turns on.
2. When the fan turns on, note the temp indication on the instrument cluster. It should be well below the 210 degree set point. Adjust the thermostat knob slightly clockwise until the fan shuts off.
3. When the fan turns on again, check the temp reading in the instrument cluster again. If the temp is below 210, adjust the knob clockwise a little more. Repeat these steps until the fan comes on at 210 on your gauge.
4. Your fan should now be cycling on and off and the needle should be steady at 210 degrees.
5. **Please make note of the thermostat setting position, as this is your reference point for adjustments from now on.**

Setting at 210 should be high enough to allow “normal” temperature regulation on the engine thermostat (195 degrees) without undue fan operation and keep you below the set points for OEM fan operation in most cases. This is a regional and seasonal variable that will be unique to each vehicle. Expect to raise the thermostat setting a few degrees in the summer to prevent undue fan operation after the engine is shut down.

You can expect:

- To see more stable coolant temperatures.
- To hear the Aux Fan cycle on and off as it pulls trapped heat from a shut down engine.
- To have improved air conditioning operation in stop and go traffic.
- To enjoy your ride more.
- To have the GM service technician ask what TSB this was.
- To have my support via PM on the Fanatic site.
- To have me available to answer a problem call at reasonable hours of the day, 7 days a week.

Please do not expect:

- To change the engine coolant thermostat to 180 degrees and force the aux fan to keep the engine at that temp. The engine is designed to run at the temp of the engine coolant thermostat or higher. The aux fan is intended to decrease the temperature swings, but not take over the main cooling function.
- To leave the thermostatic controller at a single set point all year. High ambient air temperatures in the summer (especially in AZ and TX) will make it very difficult to extract the heat out of the engine after shutdown without running the aux fan for an unacceptably long time.
- The aux fan to be silent. It is an electric motor doing work and will make a “reasonable” amount of fan/motor noise after shutdown. This is especially noticeable when it is quiet in the garage.
- To ignore the health of your OEM fan. It is still the main cooling device for your truck and should be checked periodically for proper operation. You can check low speed OEM fan operation by turning on the A/C and watching the fan come on after the engine is warm and the compressor is running. You can then select the “recirculate” function on the HVAC control and observe the OEM fan go to high speed.
- Me to answer the phone for any technical support between 9:00pm and 7:00am MST.

Periodic OEM Fan Test:

Since the Aux fan could possibly mask a failing OEM fan, it is good to understand how to test the OEM fan for proper operation. Please familiarize yourself with this simple test. It is an excellent diagnostic tool. Temporarily remove the 20 amp Aux Fan fuse to assist in this test.

- The OEM fan is commanded to **low speed** any time the A/C system is operating with normal pressures. This is a quiet mode of operation, but you will be able to see it.
- The OEM fan is commanded to **high speed** any time the A/C system is operating with normal pressures and the “Recirculate” selection has been made. You’ll hear this change when you select the button.

CAUTIONS:

- 1. This kit provides the immediate capability for the auxiliary fan to operate without the ignition on. Take adequate precautions when doing maintenance, as the fan could begin rotating at any time. Please become familiar with removing the fan fuse from the fuse holder when working on, or around the auxiliary fan.**
- 2. Installation of this kit DOES NOT, in any way, reduce the responsibility of the operator to monitor the engine indicating instruments for proper engine and systems operation.**

If you have any questions or problems, please send a PM to “Mike in AZ” on the SSR Fanatic forum at www.SSRFanatic.com or an e-mail to mike@simple-engineering.com. I can also be reached by cell phone at 480-225-2123 for critical needs. The system carries a 1 year, no hassle warranty through me. If you are not completely satisfied with this system, ship it back to me within 30 days for a full refund. No questions asked.

Enjoy the ride,

Mike

System Schematic:

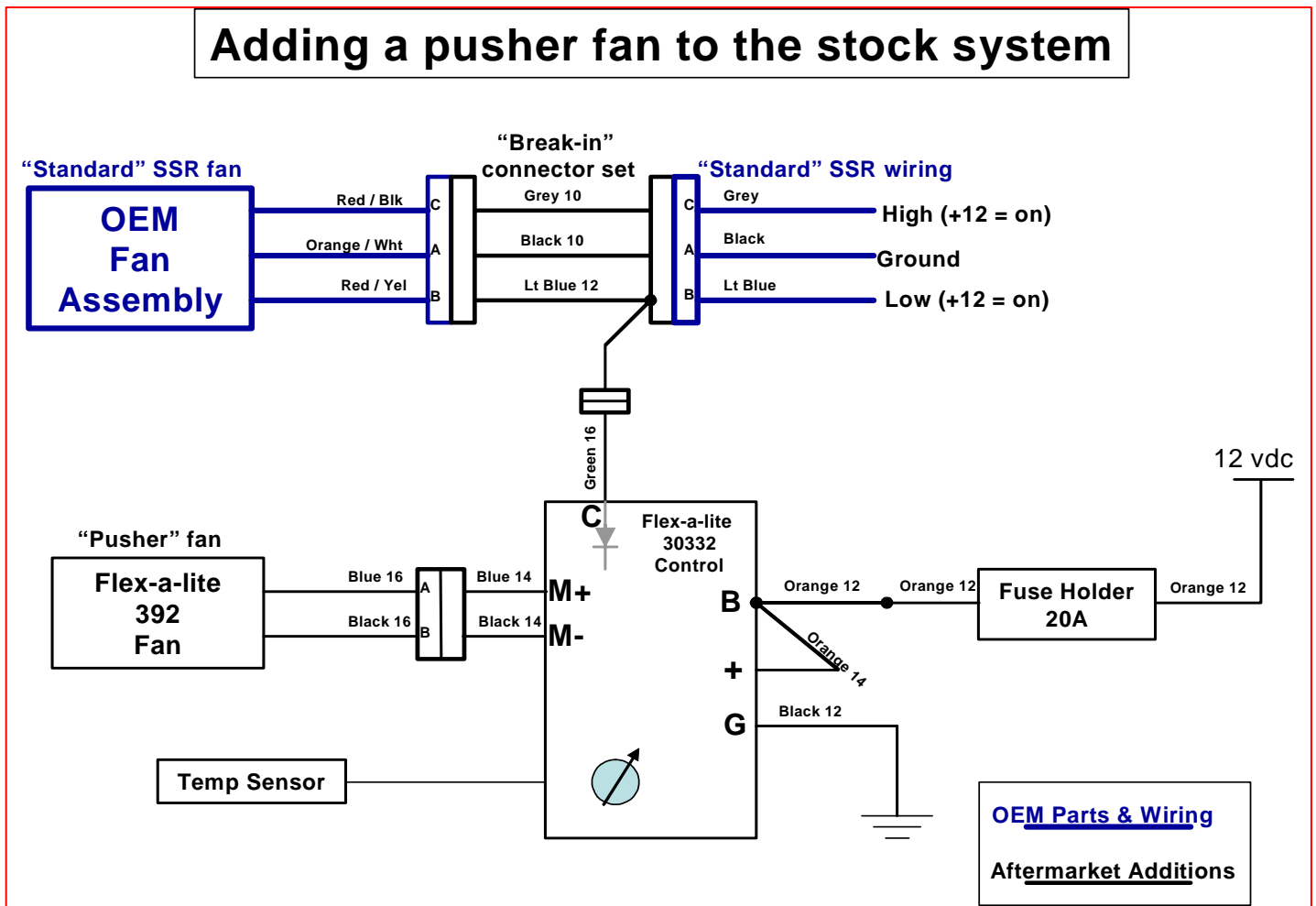

The following 3 pages are reference information from the Flex-a-Lite packaging that came with the model 392 Fan and 30332 Controller.



Replacement Adjustable Temperature Control Installation Instructions

Step 1: Locate mounting point for control

Locate a mounting point for control near inlet side of radiator. Control needs to be placed within 18" of radiator inlet hose. You may want to mount next to radiator on fender well.

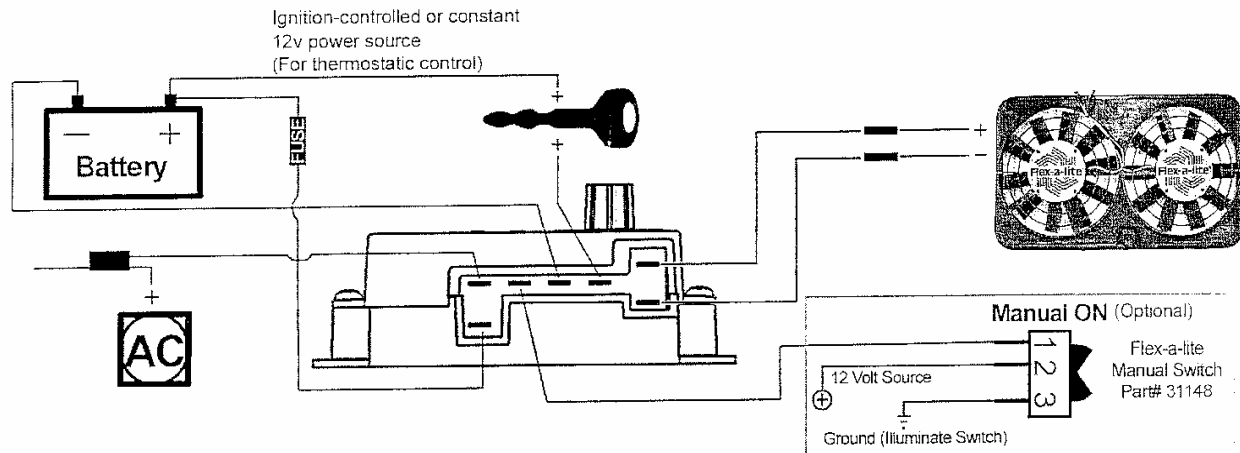

Step 2: Wire the fan motor (s) (refer to above wiring diagram. Connect the fan motor wires to the control module (positive wire to the "M+" terminal and negative motor wire to the "M-" terminal). **Note:** Be sure to use wire that is intended to handle the current (amp) rating of the fan.

Step 3: Disconnect the negative battery lead for safety while finishing the wiring. Run power directly from the battery positive (+) terminal to the "B" terminal on the control module. Connect fuse holder in-line with this wire, as shown, but do not insert the fuse yet.

Step 4: Run a wire from the negative (-) battery terminal to the "G" terminal on the control module.

Step 5: Connect the "+" terminal on the control module to a positive 12 volt power source. **NOTE:** *Attaching this wire to an ignition-controlled source will shut off the fan when the engine is turned off. Attach this wire to an uninterrupted (always hot) power source to allow the fan to continue running after the engine is shut off.*

Step 6: (Optional) For air conditioning control (if desired) connect the "C" terminal on the control module to the *positive* wire that triggers the A/C compressor. Using a voltmeter, determine which wire coming from the compressor is the *positive* trigger wire. Use the 3-way (or similar) connector to tap into this wire and send a signal to the fan control module. The fan will cycle on and off with the A/C clutch when the A/C is turned on.

(continue to next page)

06-20-05 99885 Page 1 of 2

Step 7: (Optional) For manual switch operation, use Flex-a-lite p/n 31148. Connect the switch as shown on the wiring diagram (previous page). Connect the "M" terminal on the control module to the "1" terminal on the switch. Connect the "2" terminal on the switch to a positive 12v power source. Connect terminal "3" on the switch to a good ground (for switch illumination). **NOTE: To prevent thermostatic activation (if only manual switch operation is desired), omit the lead to the "+" terminal of the control box. "B", "G", "M+" and "M-" must remain connected. If not using a Flex-a-lite manual switch, do not connect a ground wire to the switch!**

Step 8: Be sure all wires are secured and will not interfere with fan blades, belts, and pulleys in the engine compartment. Reconnect the battery and insert the fuse

Step 9: Insert the temperature probe into the radiator fins: Locate the inlet hose from the engine to the radiator. Remove the black insulator cap and insert the temp. probe through the radiator fins near the inlet hose. Reinstall the black insulator cap.



Install temp. probe near inlet hose...

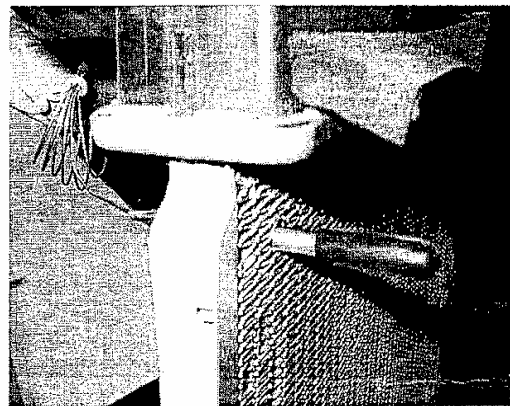

then replace the insulator cap.

Step 10: Adjust the temperature control knob on the control box

If you disconnected any hoses or drained coolant to install the fan, reconnect the hoses and refill the radiator. Press the control knob (included in kit) onto the control box shaft. Turn the knob clockwise until it stops. Start the engine and allow it to idle. Using a hand held thermometer (positioned near the inlet hose) or the vehicle's temperature gauge, monitor the temperature. When the coolant temp. is slightly above normal (or desired temp.), turn the knob counter-clockwise just until the fan turns on. From now on, the fan should activate at this temperature setting. Adjust as necessary to maintain desired temperature.

The Flex-a-lite Limited Warranty
Flex-a-lite Consolidated, 7213-45th St. Cl. E. Fife, WA 98424, Telephone No. 253-922-2700, warrants to the original purchasing user, that all Flex-a-lite products to be free of defects in material and workmanship for a period of 365 days (1 year) from date of purchase. Flex-a-lite products failing within 365 days (1 year) from date of purchase may be returned to the factory through the point of purchase, transportation charges prepaid. If, on inspection, cause of failure is determined to be defective material or workmanship and not by misuse, accidental or improper installation, Flex-a-lite will replace the fan free of charge, transportation prepaid. Flex-a-lite will not be liable for incidental, progressive or consequential damages. Some states do not allow the exclusion or limitation of incidental or consequential damages, so the above limitation or exclusion may not apply to you. This warranty gives you specific legal rights and you may have other rights, which vary from state to state.
The Flex-a-lite warranty is in compliance with the Magnuson-Moss Warranty Act of 1975.

The fan has already been reconfigured to “pusher” mode as part of the SSR Aux Fan kit preparation.



S-Blade Electric Fans

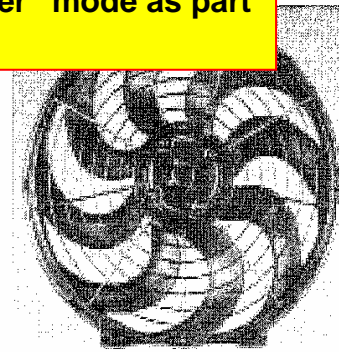

Installation Instructions

Puller Mode (as shipped from the manufacturer) Through Core Mounting Instructions (SEE DIAGRAM “A”)

1. Attach the mounting tabs to the electric fan. See diagram “A”.
2. Position the electric fan against the radiator, and mark mounting hole locations.
3. Pass a small Phillips screwdriver through the marked holes, carefully spreading the fins to allow easy passage for the nylon bolts. Fit the bolts to the mounting tabs, and pass the bolts through the shroud holes in the radiator.
4. Push on the speed nuts until snug.
5. Cut off the end of the mounting bolts, leaving 1/4” remaining.

Diagram A
Puller Mode Shown

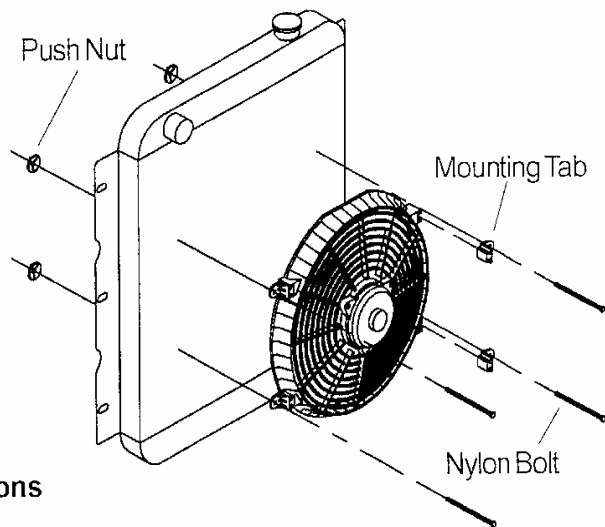

Pusher Mode Through Core Mounting Instructions

1. Remove retaining clip from motor shaft.
2. Remove fan blade, flip it over, and re-fit to shaft. Make sure that pin on shaft is seated into groove in fan hub. Replace retaining clip.
3. Proceed with instruction above. *Note: some vehicles have a/c condensers or transmission coolers mounted in front of the radiator. Modifications may be necessary to accommodate the fan.*

Wiring Instructions

Important: Pusher fans use:
Blue wire is positive (+).
Black wire is negative (-).

Important: Puller fans use:
Black wire is positive (+).
Blue wire is negative (-).

Note: Fans shipped in Puller mode. If you are mounting as a pusher, you need to flip fan blade over.

The Flex-a-lite Limited Warranty

Flex-a-lite Consolidated, 7213-45th St. Ct. E., Fife, WA 98424, Telephone No. 253-922-2700, warrants to the original purchasing user, that all Flex-a-lite products to be free of defects in material and workmanship for a period of 365 days (1 year) from date of purchase. Flex-a-lite products failing within 365 days (1 year) from date of purchase may be returned to the factory through the point of purchase, transportation charges prepaid. If, on inspection, cause of failure is determined to be defective material or workmanship and not by misuse, accidental or improper installation, Flex-a-lite will replace the fan free of charge, transportation prepaid. Flex-a-lite will not be liable for incidental, progressive or consequential damages. Some states do not allow the exclusion or limitation of incidental or consequential damages, so the above limitation or exclusion may not apply to you. This warranty gives you specific legal rights and you may have other rights, which vary from state to state. The Flex-a-lite warranty is in compliance with the Magnuson-Moore Act.

The fan has already been reconfigured to “pusher” mode as part of the SSR Aux Fan kit preparation.